

1-D Convolution Circuits in Quantum Computation

Artyom M. Grigoryan, Sos S. Agaian

Abstract— The circular, or aperiodic convolution is one of the main operations in linear systems when processing one-dimension (1-D) and multidimensional signals. In this work we describe a few quantum circuits for the 1-D convolution, by using the concept of the quantum Fourier transform. The calculation is considered for a linear time-invariant system for the case, when the frequency characteristic of the system.

Index Terms— Quantum convolution, quantum Fourier transform, quantum computation.

1 Introduction

THE concepts of the discrete Fourier transform (DFT) and linear convolution are very important in processing signals [1], [2], [3]. The linear convolution is the operation of a linear time-invariant (LTI) system and its fast realization is accomplished by the DFT. The quantum circuits for the quantum Fourier transform (QFT) are known [4], [5], [6], [7], [8]. The design of the quantum circuits for the circular and linear convolutions is still the open problem, even if we try to calculate this operation by the periodic patterns of the signals [9]. The traditional method of reducing the circular convolution of signals to the multiplication of their DFTs has not found yet implementation in quantum computation.

In this work, we present our view on the solution of the problem of calculation of the convolution, by using the QFT. A few quantum circuits are discussed for the convolution in linear invariant systems or filters, under the assumption that the impulse response or the frequency characteristic of the systems and filters are known.

2 Method of Quantum Convolution

Let us consider the following operations over the input signal and given characteristic of a LTA system or filter. For simplicity of calculations, we assume that the signal f_n of length N and the characteristic H_p were normalized, i.e.,

$$\sum_{n=0}^{N-1} |f_n|^2 = \sum_{p=0}^{N-1} |H_p|^2 = 1.$$

N is a power of two, $N = 2^r, r > 1$.

1. Compose the following $(r + 1)$ quantum mixed-type superposition of states:

$$|\varphi\rangle = |\varphi_{r+1}\rangle = |1\rangle|\check{f}\rangle + |0\rangle|\check{H}\rangle \\ = |1\rangle \sum_{n=0}^{N-1} f_n|n\rangle + |0\rangle \sum_{p=0}^{N-1} H_p|p\rangle. \quad (1)$$

- Artyom Grigoryan, Associate Professor at the Department of Electrical and Computer Engineering University of Texas at San Antonio, San Antonio, TX 78249-0669, E-mail: amgrigoryan@utsa.edu
- Sos Agaian, Professor at the Computer Science Department, The College of Staten Island, New York, USA, E-mail: Sos.Agaian@csi.cuny.edu

Here, the normalized coefficient $1/\sqrt{2}$ is omitted, and $|n\rangle$ and $|p\rangle$ are the basic states. The circuit element for such a superposition is shown in Fig. 1.

2. Use the first qubit as a control qubit and perform the r -qubit QFT over the superposition of the signal. The result is the following $(r + 1)$ -qubit superposition:

$$|\varphi\rangle \rightarrow |\Psi\rangle = |1\rangle|\check{F}\rangle + |0\rangle|\check{H}\rangle \\ = |1\rangle \sum_{p=0}^{N-1} F_p|p\rangle + |0\rangle \sum_{p=0}^{N-1} H_p|p\rangle, \\ |\Psi\rangle = \sum_{p=0}^{N-1} (|1\rangle F_p + |0\rangle H_p) |p\rangle. \quad (2)$$

The realization of the r -qubit QFT can be accomplished by the paired transform-based algorithm [6].

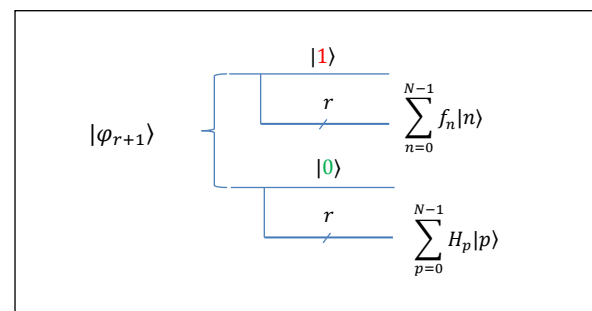

Fig. 1. The circuit element for the $(r + 1)$ -qubit state $|\varphi_{r+1}\rangle$.

3. Process each 1-qubit state $|\phi_p\rangle = |1\rangle F_p + |0\rangle H_p$ by the diagonal matrix

$$V_p = \begin{bmatrix} 1/H_p & 0 \\ 0 & H_p \end{bmatrix}, \quad (3)$$

if $H_p \neq 0$, otherwise consider the matrix

$$V_p = \begin{bmatrix} 1 & 0 \\ 0 & 0 \end{bmatrix}.$$

We can consider that $H_p \neq 0$, for all frequency-points $p = 0: (N - 1)$. Otherwise, if this frequency characteristic has zeros, a constant can be added to H_p and considered $H_p = H_p + \text{const}$. Indeed, the inverse N -point DFT of the constant is the unit impulse with amplitude equal to this constant, i.e., $\text{const} \times \delta_n$. Therefore, the convolution changes as

$$f_n \otimes (h_n + \text{const} \times \delta_n) = f_n \otimes h_n + \text{const} \times f_n.$$

Because the const is known, as well the input signal, the component $\text{const} \times f_n$ can be removed from the convolution on the final stage of calculations. Thus, we assume that $H_p \neq 0$ for all $p = 0: (N - 1)$.

As the result, we obtain the qubit in the state

$$V_p |\phi_p\rangle = V_p \begin{bmatrix} H_p \\ F_p \end{bmatrix} = \begin{bmatrix} 1 \\ H_p F_p \end{bmatrix} = |1\rangle H_p F_p + |0\rangle, \quad (4)$$

which after the normalization will be written as

$$V_p |\phi_p\rangle = \frac{1}{\sqrt{1 + |H_p F_p|^2}} (|1\rangle H_p F_p + |0\rangle).$$

In matrix form, the action of all matrices $V_p, p = 0: (N - 1)$, can be described by the following $(2N) \times (2N)$ diagonal matrix:

$$V = V(H) = A \oplus B.$$

The diagonal matrices in this Kronecker sum are

$$A = \text{diag}\{a_{p,p}\}_{p=0:(N-1)}, \quad a_{p,p} = 1/H_p, \quad (5)$$

$$B = \text{diag}\{b_{p,p}\}_{p=0:(N-1)}, \quad b_{p,p} = H_p. \quad (6)$$

The new $(r + 1)$ -qubit superposition is

$$\begin{aligned} |\tilde{\Psi}\rangle = V|\Psi\rangle &= \frac{1}{K} \sum_{p=0}^{N-1} (|1\rangle H_p F_p + |0\rangle) |p\rangle = \\ &= |1\rangle \frac{1}{K} \sum_{p=0}^{N-1} H_p F_p |p\rangle + |0\rangle \frac{1}{K} \sum_{p=0}^{N-1} |p\rangle. \end{aligned} \quad (7)$$

Here, the coefficient K equals

$$K = \sqrt{\sum_{p=0}^{N-1} |H_p F_p|^2 + N}.$$

- Use the first qubit as a control qubit and perform the inverse r -qubit QFT of the obtained quantum superposition,

$$\sum_{p=0}^{N-1} H_p F_p |p\rangle \rightarrow |\tilde{y}\rangle = \sum_{n=0}^{N-1} y_n |n\rangle. \quad (8)$$

Here, y_n is the circular convolution

$$y_n = (f \otimes h)_n = \sum_{k=0}^{N-1} f_k h_{(k-n) \bmod N}, \quad (9)$$

for $n = 0: (N - 1)$. The normalized coefficients

$$\sqrt{\sum_{p=0}^{N-1} |H_p F_p|^2} \quad \text{and} \quad \sqrt{\sum_{n=0}^{N-1} y_n^2}$$

are equal up to the coefficient $1/\sqrt{N}$ (because of Parseval's equality) and omitted in the sums in Eq. 8, for simplicity of writing.

It should be noted that the inverse r -qubit QFT can also be used without the controlled qubit. Indeed, as follows from Eq. 7, the r -qubit superposition at the first qubit, when it is in the state $|0\rangle$, describes the r -qubit QFT with vales all equal to 1. The constant signal is represented by such a superposition,

$$\{1, 1, \dots, 1\} \rightarrow \frac{1}{\sqrt{N}} \sum_{p=0}^{N-1} |p\rangle. \quad (10)$$

Therefore, the inverse r -qubit QFT over this superposition is the unit impulse, i.e.,

$$\frac{1}{\sqrt{N}} \sum_{p=0}^{N-1} |p\rangle \rightarrow \sum_{n=0}^{N-1} \delta_n |n\rangle = |00 \dots 0\rangle. \quad (11)$$

If apply the inverse r -qubit QFT to the last r qubits without using the first qubit as a controlled qubit, then according to Eqs. 7 and 11, we obtain the following superposition:

$$\begin{aligned} IQFT |\tilde{\Psi}\rangle &= \frac{1}{M} \left(|1\rangle \sum_{n=0}^{N-1} y_n |n\rangle + |0\rangle |00 \dots 0\rangle \right) \\ &= \frac{1}{M} (|1\rangle |\tilde{y}\rangle + |0\rangle |00 \dots 0\rangle). \end{aligned} \quad (12)$$

The normalized coefficient equals to

$$M = \sqrt{1 + \sum_{n=0}^{N-1} y_n^2}.$$

The information of the frequency characteristic H_p is used on stage 3 of the above algorithm, to compose the matrices V_p . This fact is very important to mention, because otherwise it would be necessary to calculate the r -qubit QFT of h_n , and then to measure all values H_p of the frequency characteristic, which would be very difficult to accomplish in the middle of calculation.

The quantum circuit for implementing the above algorithm of the circular convolution of the signal f_n is shown in Fig. 2.

In Fig. 3, the quantum circuit for the circular convolution is given with more details, with the superpositions on each stage. These superpositions are written without the corresponding normalized coefficients, in view of the limited space in the drawing.

If use the r -qubit inverse QFT with the controlled first qubit, the quantum circuit for the circular convolution can be drawn, as shown in Fig. 4. The measurements of the obtained r -qubit superposition when the first qubit in the state $|0\rangle$ will give always the result equal 1.

3 Circuits for the Linear Convolution

Because the linear convolution of two signals can be reduced to the circular convolution after zero padding the signals, the above quantum circuits can be used to calculate the linear convolution. The zero padding may enlarge the qubit representation of the signal, but only by one qubit. We consider the case, when the length L_1 of the signal f_n and the length L_2 the impulse response h_n are such that, $M = L_1 + L_2 - 1 \leq N = 2^r$. Then, we denote the zero padded signals of length N by

$$\{\tilde{f}_n; n = 0: (N - 1)\} = \{\{f_n; n = 0: (L_1 - 1)\}, 0, 0, \dots, 0\}$$

$$\{\tilde{h}_n; n = 0: (N - 1)\} = \{\{h_n; n = 0: (L_2 - 1)\}, 0, 0, \dots, 0\}$$

and their N -point DFT by \tilde{F}_p and \tilde{H}_p , respectively. The quantum circuit in Fig. 3, which was modified for calculation of the linear convolution

$$y_n = f_n * h_n = \tilde{f}_n \circledast \tilde{h}_n, \quad n = 0: (N - 1),$$

is given in Fig. 5. The input is the $(r + 1)$ qubit mixed-type superposition of states

$$\begin{aligned} |\varphi\rangle &= |\varphi_{r+1}\rangle = |1\rangle|\tilde{f}\rangle + |0\rangle|\tilde{H}\rangle \\ &= |1\rangle \sum_{n=0}^{L_1-1} f_n |n\rangle + |0\rangle \sum_{p=0}^{N-1} \tilde{H}_p |p\rangle. \end{aligned} \quad (13)$$

3.1. Circular Convolution with Direct Calculation

It could be noted that from very beginning we could consider a simple quantum circuit which is similar to the circuit for the circular convolution in the classical computer. Indeed, let us assume that the V-type matrix is applying only on the r -qubit QFT of the signal, as shown in Fig. 6.

In this diagram, the matrix V_r is considered to be equal to the diagonal matrix $N \times N$

$$V_r = \text{diag}\{H_0, H_1, \dots, H_{N-1}\}, \quad (14)$$

where diag denotes the diagonal matrix. The normalized coefficient for this matrix is $1/\sqrt{H_0 H_1 \dots H_{N-1}}$, when all coefficients of the frequency characteristic are not zero, $H_p \neq 0, p = 0, 1, \dots, (N - 1)$. How to implement the multiplication by this matrix is a question. In addition, this coefficient maybe very large even for small values of N . For instance, the frequency characteristic for the impulse response $h = [1 \ 2 \ 3 \ 2 \ 1]/9$ after

zero padding is shown in Fig. 7 in absolute scale for the $N = 128$ case. The square root $R = \sqrt{H_0 H_1 \dots H_{N-1}} = 2.5445 \times 10^{-61}$, and for the $N = 64$ and 32 cases, this number equals to $R = 8.7370 \times 10^{-31}$ and 1.6190×10^{-15} , respectively. Note that, in the quantum circuits of the circular convolution, which are given in Figs. 3 and 4, all 2×2 matrices V_p in Eq. 3 have determinant equal 1.

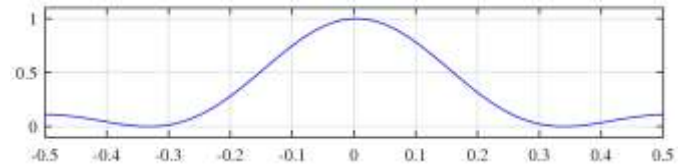

Fig. 7. The magnitude of the frequency characteristic H_p of the filter $h_n = [1 \ 2 \ 3 \ 2 \ 1]/9$.

4 CONCLUSION

The possible quantum circuits for calculation the linear and circular convolution on qubits were discussed. The method of calculation of convolutions in these circuits is based on the quantum Fourier transform. The convolution is considered for the case when the frequency characteristic of the linear-time-invariant system is known.

REFERENCES

- [1] Elliot D.F., Rao K.R.: Fast Transforms-Algorithms, Analyzes, and Applications. Academic Press, San Diego, 1982.
- [2] Blahut R.E.: Fast Algorithms for Digital Signal Processing. Addison-Wesley, Reading, 1985.
- [3] Grigoryan A.M., Grigoryan M.M.: Brief Notes in Advanced DSP: Fourier analysis with MATLAB, CRC Press Taylor and Francis Group, 2009.
- [4] Perez L.R., Garcia-Escartin J.C.: Quantum arithmetic with the quantum Fourier transform, *Quantum Information Processing*, vol. 16, p. 14, 2017.
- [5] Karafyllidis, I.G.: Visualization of the quantum Fourier transform using a quantum computer simulator. *Quantum Inf. Process.* **2**(4), 271–288, 2003.
- [6] Grigoryan A.M., Agaian S.S.: Paired quantum Fourier transform with $\log_2 N$ Hadamard gates, *Quantum Information Processing*, vol 18: 217, p. 26 (2019)
- [7] H.S. Li, P. Fan, H. Xia, S. Song, He X.: The quantum Fourier transform based on quantum vision representation, *Quantum Information Processing*, vol. 17:333, p. 25 (2018).
- [8] Perez L.R., Garcia-Escartin J.C.: Quantum arithmetic with the quantum Fourier transform, *Quantum Information Processing*, vol. 16, p. 14, 2017.
- [9] Grigoryan A.M.: Resolution map in quantum computing: Signal representation by periodic patterns, *Quantum Information Processing*, vol. 19: 177, p. 21, 2020.

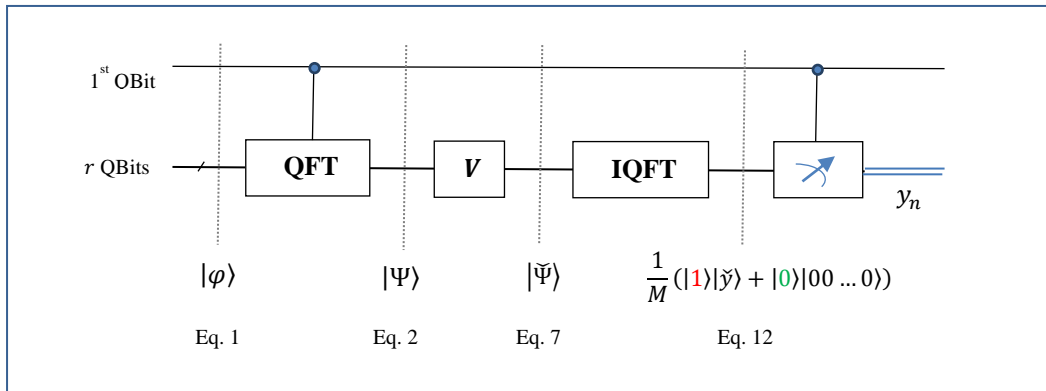

Fig. 2. The quantum circuit for the circular convolution y_n of the signal.

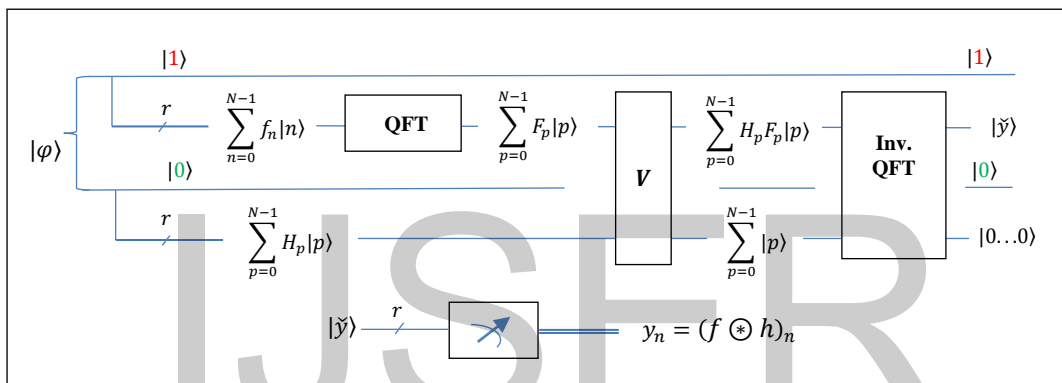

Fig. 3. The quantum circuit for the circular convolution y_n of the signal.

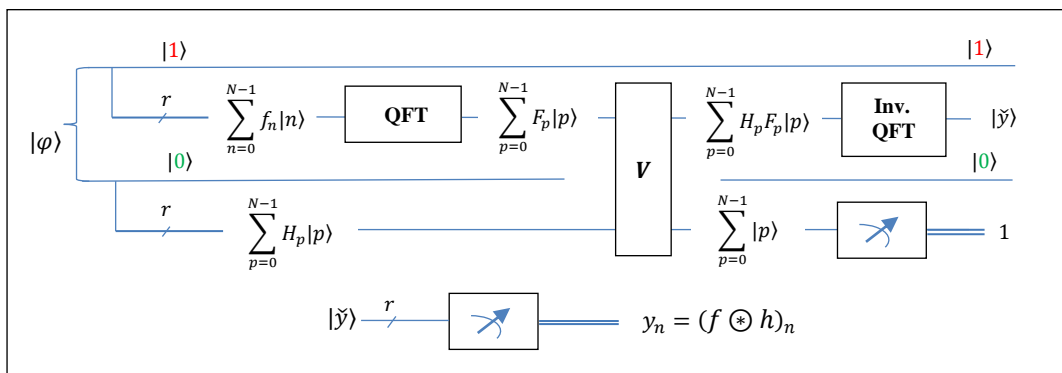

Fig. 4. The second quantum circuit for the circular convolution y_n .

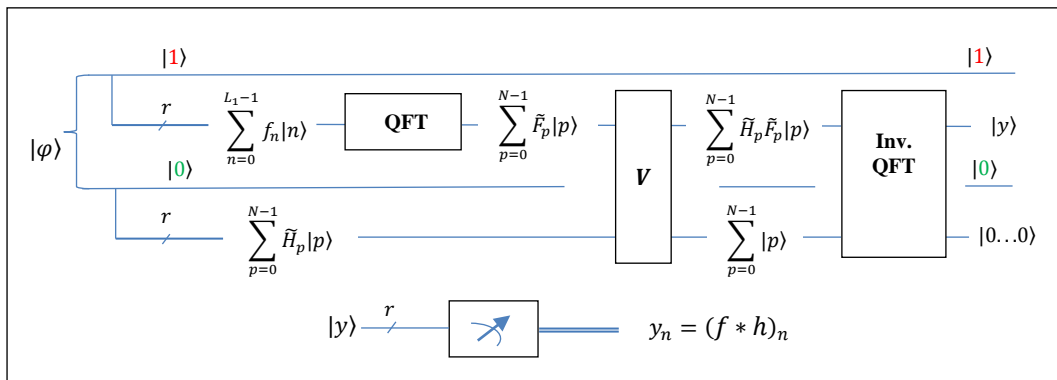

Fig. 5. The quantum circuit for the linear convolution y_n of the signals.

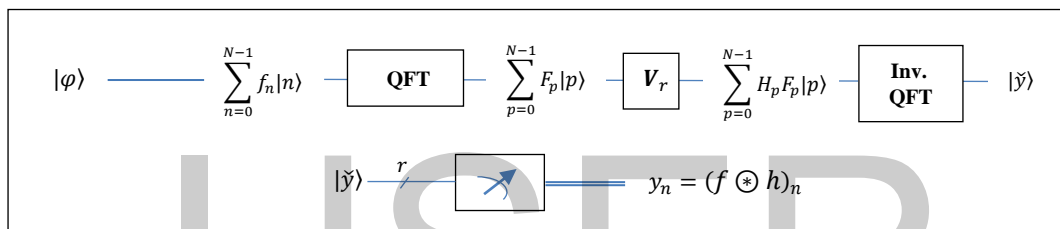

Fig. 6. The quantum circuit with r qubits for the circular convolution y_n .